

Belt Scales

IN-MOTION
BELT SCALE SOLUTIONS



RICE LAKE[®]
WEIGHING SYSTEMS

800-472-6703
www.ricelake.com

Belt Scales

Keep Production Moving with In-Motion Belt Scale Systems

Belt scales are the most accurate and efficient way to measure material flow on a conveyor belt and can also be used for product dosing. A belt scale consists of a weigh frame with one or more load cells, a speed sensor and a weigh processor. The weigh processor converts data received from the load cell and speed sensor into a total and weight per hour.

The selection of a weigh frame and speed sensor is determined by the required accuracy, as well as belt speed, inclination and structure of the transport belt.

Rice Lake Weighing Systems offers a broad selection of rugged and accurate belt scales. With six different models to choose from, Rice Lake belt scales provide a solution for nearly every application, including food, recycling, chemical, steel, animal feed and compost production, sand and gravel quarries, and harbor logistics industries.



221DB

The 221DB Master™ belt scale weigh frame consists of two arms equipped with a pivot and a load cell mounted to the side supports of the conveyor belt. The idler, or weighing roller, is mounted on top of the frame arms. The 221DB provides simple assembly and accessibility for service. Suitable for most belt widths and capacities, the 221DB is a versatile solution for many applications.

Standard Features

- Weigh frame is mounted on outside of conveyor
- Minimum modifications to conveyor are required
- Service friendly
- Friction-free pivot supports
- Two support beams
- Fits standard conveyors—mounts with four bolts per assembly

Options

- Galvanized or stainless construction

Applications

- Medium to heavy capacity

Specifications

- Conveyor Width:**
18 in to 72 in (500 mm-2,400 mm)
- Capacity:**
3,300 tons per hour
- Maximum Belt Speed:**
800 feet per minute (4 m/s)
- Inclination:**
Maximum 25 degrees
- Material:**
Powder coated mild steel
- System Accuracy**
0.5-1%
- Load Cell:**
RLHBB: 50 kg, 100 kg, 200 kg
- Junction Box:**
JB4SS
- Warranty:**
One-year limited warranty



311M

Consisting of an idler or weighing roller placed on a simple load cell beam, the 311M Master belt scale weigh frame is a cost effective solution. Suitable for belt widths up to 36 inches and belt speeds up to 400 feet per minute, the 311 frame is often used for belts that can regulate the capacity of a bulk flow using the measured value and a controlled belt speed.

Standard Features

- Semi-modular weigh frame design
- Weigh frame without moving parts
- Fits standard conveyors
- Mounts with four bolts
- Requires weigh frame cutting for proper fit
- Minimum modifications to conveyor required

Options

- Galvanized or stainless construction
- Custom widths available

Applications

- Mining, quarries, bulk material blending, process control and retrofit

Specifications

- Conveyor Width:**
18 in to 36 in (1,500 mm max)
- Capacity:**
1,500 tons per hour
- Belt Speed:**
Maximum 400 feet per minute (2 m/s)
- Inclination:**
Maximum 12 degrees
- Material:**
Powder coated mild steel
- System Accuracy:**
1%
- Load Cell:**
RL1250: 50 kg, 100 kg, 250 kg
- Warranty:**
One-year limited warranty



211

The 211 Master belt scale weigh frame consists of an inner frame mounted with two friction-free pivots to one end of the scale. The load cell is located on the opposite end with the idler mounted on the inner frame. The friction-free pivots absorb tensile stress in a horizontal direction, creating a very solid weigh frame well-suited for heavy-duty applications.

Standard Features

- Friction-free pivot points
- One load cell carrier beam
- Fits standard conveyors
- Custom built for each application

Options

- 304/316 stainless steel
- Dual load cells

Applications

- Medium to heavy capacity, mining and agriculture

Specifications

Conveyor Width:
20 in to 80 in (500 mm to 2,000 mm)

Capacity:
3,000 tons per hour

Maximum Belt Speed:
800 feet per minute (4 m/s)

Maximum Inclination:
25 degrees

Material:
Powder coated mild steel

System Accuracy:
0.5%

Load Cell:
RL20001 alloy steel, s-beam (capacity selected from application)

Warranty:
One-year limited warranty



143

Weigh three idlers on an inner frame, supported by four load cells with the 143 Master belt scale weigh frame. This creates an incredibly accurate belt scale qualified for high capacities and belt speeds. The 143 is often used in mining and aggregate applications. The frame is custom made using the specifications of the conveyor belt, making it suitable for different belt conveyor models.

Standard Features

- Custom built for each application
- Fits standard conveyors
- Multiple idler design
- Inner frame has free, floating platform

Options

- 304 stainless steel
- Two, three, or four weigh idlers

Applications

- Medium to heavy capacity, mining and aggregate

Specifications

Conveyor Width:
20 in to 120 in (500 mm to 3,000 mm)

Capacity:
20,000 tons per hour

Belt Speed:
1,400 feet per minute (7 m/s)

Inclination:
25 degrees

Material:
Powder coated mild steel

System Accuracy:
0.25%

Load Cell:
RL20001 alloy steel s-beam (capacity selected from application)

Warranty:
One-year limited warranty



421

The 421 Master belt scale weigh frame is specifically designed for high volume, low density applications where belt load and belt speed are moderate. Ideal for flat belt conveyors, the 421 features two BM11 bending beams and hermetically sealed load cells mounted to adjusting plates on the outside of the conveyor stringers to create a stable base. The 421 master belt scale is also available for hazardous and explosive areas.

Standard Features

- Ideal for flat belt conveyors
- Roller supported on both sides by load cells
- Open design for easy cleaning

Applications

- Light capacity, food production and light granular materials

Specifications

Conveyor Width:
12 in to 60 in (300 mm to 1,600 mm)

Capacity:
30 tons per hour

Belt Speed:
400 feet per minute (2 m/s)

Inclination:
10 degrees

Material:
Powder coated mild steel / 304 / 316 stainless steel

System Accuracy:
0.5%

Load Cell:
RLHBB single ended beam in 10, 20 or 50 kg capacities

Warranty:
One-year limited warranty

Belt Scales



BCi Weigh Frame

Experience durability and accuracy with Rice Lake's rugged BCI belt scale weigh frame. Built to last, the BCI is one of the most accurate belt scales in its class. Ideal for mining, quarries, bulk material blending, process control operations and load-out applications, the BCI easily handles capacities up to 10,000 tons per hour with unsurpassed accuracy.

Applications

- Mining, quarries, bulk material blending, process control, utilities, truck/barge/rail loading and retrofit

Specifications

Conveyor Widths:

18 in to 72 in (450 mm-1,800 mm)

Capacity:

Up to 10,000 tons per hour

Belt Speed:

Up to 1,200 feet per minute (7 m/s)

System Accuracy:

Single and two idler system: 0.5%-1% total error

Three and four idler system: <0.5% total error

Accuracy Guidelines:

Guidelines assume clean belt with automatic tensioning system. Accuracy guidelines are typical. System accuracy may vary depending on environmental influences.

Lifting Weights

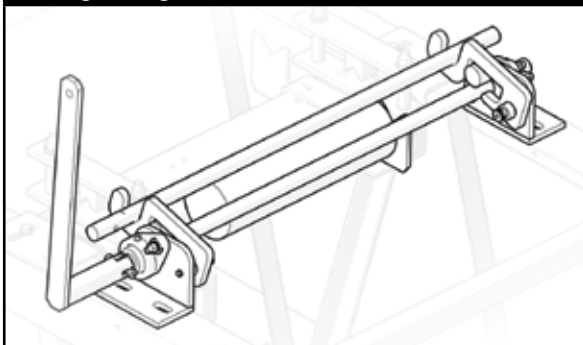

**Custom lifting weights available upon request.*



882D

Specifically designed with belt scales in mind, the 882D belt scale integrator delivers the required data in a compact package. Featuring iRite™ programmability, it can be customized to control product dosing or manage metering. The 882D's backlit display makes viewing rate, speed and time convenient in virtually any lighting condition. The 882D is also protected from the elements in an IP66 stainless steel enclosure, making it ideal for use in harsh environments.

Standard Features

- LCD display, seven-digit, seven-segment weight display, 3 x 20 pixelated prompt area
- RS-232 or RS-485 serial port
- USB device port connects directly to a PC
- Ethernet TCP/IP polled or continuous
- AC or DC models
- Hardware slot for two option cards
- Operator functions through menu key for audit trail, preset tare, accumulator, time/date and setpoints
- Audit trail tracking for configuration and calibration changes
- Password protection for user and configuration changes
- Setpoints for control and alarms
- Four onboard digital I/O channels
- Four programmable ticket formats up to 1,000 characters
- Filter settings for light, medium and heavy noise
- Speed inputs

Specifications

Analog Output:

16-bit resolution, 0-10 VDC, 0-20 mA, 4-20 mA

Relay Board:

Four dry contact relays; DC Max: 30 VDC at 3 amps

AC max: 250 VAC at 3 amps per contact

EtherNet/IP Interface:

According to EN 50325-2

PROFINET Interface:

According to IEC 61784 (CPF-3/3)

Modbus/TCP Interface:

Up to 8 bytes of I/O data, 100 Mbps full duplex Ethernet

DeviceNet Interface:

According to EN 50325-2

Profibus DP® Interface:

According to EN 50170

EtherCAT:

According to IEEE 802.3

Digital I/O:

24 channel I/O expansion boards available

Approvals:

CE Marked

UL/c-UL Listed

Your Rice Lake Weighing Systems distributor is:

RICE LAKE
WEIGHING SYSTEMS

230 W. Coleman St. • Rice Lake, WI 54868 • USA
TEL: 715-234-9171 • FAX: 715-234-6967 • www.ricelake.com

An ISO 9001 registered company © 2018 Rice Lake Weighing Systems PN 95556 2/18
Specifications subject to change without notice.